

RCB005

5 Bit Voltage Regulator Module (VRM) for Pentium[®] II Processors For 5V Power Supply

Features

- Programmable 1.3V to 3.5V output
- Output current to 15A
- 5-bit digital input selects output voltage
- Typical efficiency > 85%
- DC output accuracy within $\pm 60\text{mV}$
- Current limiting short-circuit protection
- Power Good output
- Output Enable function
- Excellent transient response
- Meets Intel VRM specifications

Applications

- Pentium II motherboard VRM module
- Programmable power supply module
- Template for motherboard implementation

Description

The RCB005 is a programmable DC-DC VRM designed to deliver the selectable processor core voltage required by Pentium II microprocessors. This VRM allows board designers to support the entire Pentium II processor family with a single motherboard design, by converting the +5V power supply voltage to the voltage required by the CPU. The RCB005 takes full advantage of Raytheon's RC5051 programmable DC-DC controller IC, utilizing synchronous architecture for maximum efficiency. This VRM integrates a 5-bit DAC function, Power Good, and Output Enable features. The result is a VRM with a minimum number of components that achieves high reliability at a competitive cost.

The RCB005 provides an extremely well regulated selectable output voltage from 1.3V to 3.5V. Voltage selection is accomplished through a 5-bit digital input. The Power Good output provides a logic LOW when an out-of-tolerance voltage is detected at the VRM output. Other features include high efficiency, short-circuit and over-voltage protection, output enable, and low package weight. The RCB005 VRM module is designed as a point-of-load converter for Pentium Pro processors, minimizing the distribution losses normally occurring when drawing high currents from a centralized power supply.

Block Diagram

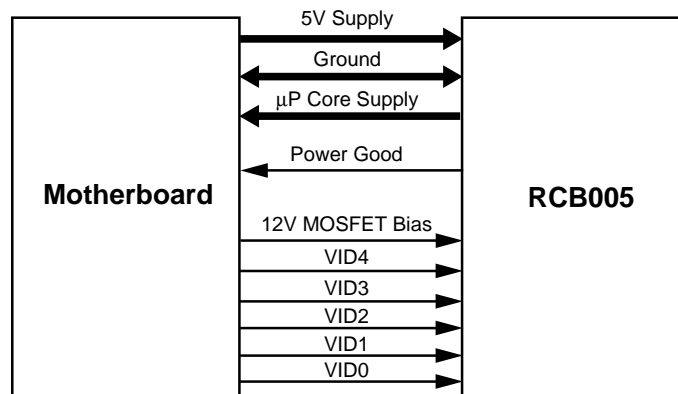

65-RCB005-1

Pin Orientation —Top View

(Socket: AMPMOD2 532956-7 or equivalent)

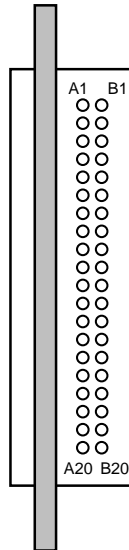

65-RCB005-2

Table 1. RCB005 Pin Definitions

Pin #	Row A	Row B
1	5Vin	5Vin
2	5Vin	5Vin
3	5Vin	5Vin
4	12Vin	12Vin
5	12Vin	NC ¹
6	NC ¹	OUTEN
7	VID0	VID1
8	VID2	VID3
9	VID4	PWRGD
10	VCCCORE	Vss
11	Vss	VCCCORE
12	VCCCORE	Vss
13	Vss	VCCCORE
14	VCCCORE	Vss
15	Vss	VCCCORE
16	VCCCORE	Vss
17	Vss	VCCCORE
18	VCCCORE	Vss
19	Vss	VCCCORE
20	VCCCORE	Vss

Note:

1. Not used on module; no current is drawn.

VRM Connector Pin Reference

Pin Description	Input/Output	Function
5Vin	I	Primary module supply voltage.
12Vin	I	MOSFET bias supply voltage.
OUTEN (Output Enable) Open collector TTL input.	I	If OUTEN = HIGH (floating), output enabled. If OUTEN = LOW, output disabled and PWRGD output LOW.
VID0 to VID4 (Voltage Identification Code) Open collector TTL inputs.	I	These five signals are used to indicate the voltage required by the processor. See Table 2.
PWRGD (Power Good) Open collector TTL output.	O	If PWRGD = HIGH, output voltage within specifications. If PWRGD = LOW, output voltage not within $\pm 10\%$ of nominal. The PWRGD output will change to the proper state within 5ms of the output coming into or going out of its specified range.
VCCCORE	O	Processor core voltage.
Vss	I, O	Ground.

Electrical Specifications

5Vin = +5V, 12Vin = +12V, TA = 0°C to 60°C, VCCORE = 2.8V, and airflow of 100LFM, unless otherwise specified.

Parameter		Test Conditions	Min.	Typ.	Max.	Units
Input Specifications						
Primary Module Supply, 5Vin			4.75	5	5.25	V
MOSFET Bias Supply, 12Vin			11.4	12	12.6	V
Output Specifications						
Output Voltage Range, VCCORE		See Table 2	1.3		3.5	V
Output Voltage Regulation	Steady State ²	VCCORE = 2.8V, ICCORE, Max = 14.2A	2.74	2.80	2.90	V
	Transient ³	VCCORE = 2.8V, ICCORE = 0.8 to 13.8A	2.67	2.80	2.93	
Output Voltage Regulation	Steady State ²	VCCORE = 1.8V, ICCORE, Max = 15.0A	1.74	1.80	1.86	V
	Transient ³	VCCORE = 1.8V, ICCORE = 0.8 to 12.8A	1.70	1.80	1.90	
Output Current, ICCORE			0.3		15	A
Initial Voltage Setpoint		ICCORE = 6A, TA = 25°C		±20		mV
Load Regulation		ICCORE = 0.8A to 15A		-40		mV
Line Regulation		5Vin = 4.75V to 5.25V		±2		mV
Output Ripple		20MHz BW, ICCORE = 15A		20		mVp-p
Output Temperature Drift				+10		mV
Efficiency		ICCORE = 0.5A	40	67		%
		ICCORE = 15A	80	83		
Turn-on Response Time					10	ms
General Specifications						
Switching Frequency				300		kHz
Short Circuit Protection				18		A

Notes:

1. The voltage tolerance is measured at the DC-DC converter Header Output on the motherboard.
2. The Steady State Voltage Regulation includes Initial Voltage Setpoint, DC load regulation, Output Ripple and temperature drift, measured with a digital voltmeter with 1mV resolution. ICCORE, MIN = 0.1A unless otherwise specified.
3. The output voltage is measured using the Intel provided EMT Tester (Rev. 1.0). It is assumed that a minimum of 20 x 0.1µF ceramic capacitors are placed directly next to the CPU to provide adequate high-speed decoupling. Additional bulk capacitors may be required as closely as possible to the CPU socket on the motherboard when using the VRM. See Application Bulletin AB 5 for details.

Mechanical Dimensions (mm)

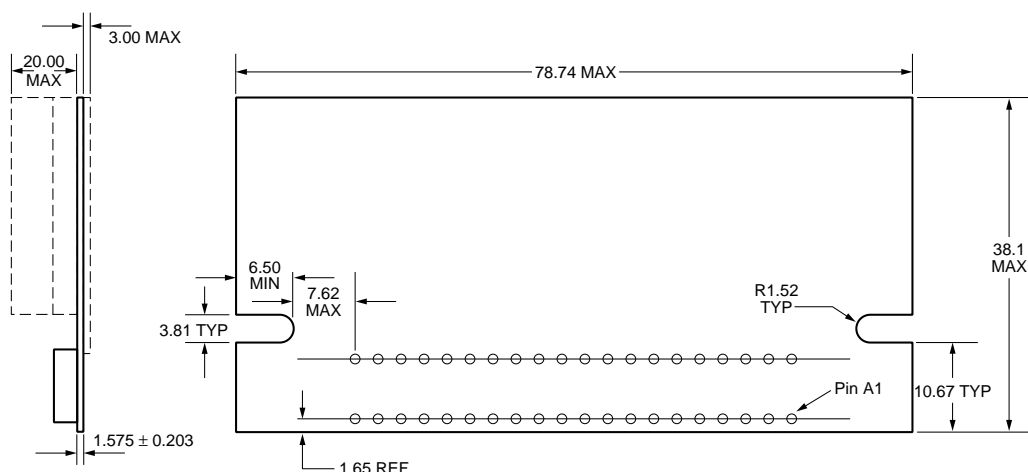

Table 2. Output Voltage vs. Voltage Identification Code

VID4	VID3	VID2	VID1	VID0	Nominal Voltage to CPU (V _{CC} CORE)
0	1	1	1	1	1.30V
0	1	1	1	0	1.35V
0	1	1	0	1	1.40V
0	1	1	0	0	1.45V
0	1	0	1	1	1.50V
0	1	0	1	0	1.55V
0	1	0	0	1	1.60V
0	1	0	0	0	1.65V
0	0	1	1	1	1.70V
0	0	1	1	0	1.75V
0	0	1	0	1	1.80V
0	0	1	0	0	1.85V
0	0	0	1	1	1.90V
0	0	0	1	0	1.95V
0	0	0	0	1	2.00V
0	0	0	0	0	2.05V

VID4	VID3	VID2	VID1	VID0	Nominal Voltage to CPU (V _{CC} CORE)
1	1	1	1	1	2.0V
1	1	1	1	0	2.1V
1	1	1	0	1	2.2V
1	1	1	0	0	2.3V
1	1	0	1	1	2.4V
1	1	0	1	0	2.5V
1	1	0	0	1	2.6V
1	1	0	0	0	2.7V
1	0	1	1	1	2.8V
1	0	1	1	0	2.9V
1	0	1	0	1	3.0V
1	0	1	0	0	3.1V
1	0	0	1	1	3.2V
1	0	0	1	0	3.3V
1	0	0	0	1	3.4V
1	0	0	0	0	3.5V

Note:

- "0" indicates processor pin is tied to 0V (VSS), "1" indicates it is tied to 5V or is open.

Ordering Information

Part Number	Input	Output Current
RCB005	5V DC	15A

The information contained in this data sheet has been carefully compiled; however, it shall not by implication or otherwise become part of the terms and conditions of any subsequent sale. Raytheon's liability shall be determined solely by its standard terms and conditions of sale. No representation as to application or use or that the circuits are either licensed or free from patent infringement is intended or implied. Raytheon reserves the right to change the circuitry and any other data at any time without notice and assumes no liability for errors.

LIFE SUPPORT POLICY:

Raytheon's products are not designed for use in life support applications, wherein a failure or malfunction of the component can reasonably be expected to result in personal injury. The user of Raytheon components in life support applications assumes all risk of such use and indemnifies Raytheon Company against all damages.

Raytheon Electronics
Semiconductor Division
350 Ellis Street
Mountain View, CA 94043
415.968.9211
FAX 415.966.7742